

1. Examine goods to assure quantity and quality is as ordered. Lay out the work to be completed, including all parts, along the base of the wall. The installer may need to supply condition appropriate hardware for use on concrete, block, or other non-typical wall surface.
2. Measure, mark, and cut the paper rail to size if necessary. Remove the end cap from the cut-off and insert into the piece to be installed (a roller may need to be cut or removed).
3. Find the location for the installation. Using a level, mark a horizontal pencil line from end to end at the paper rail location.
4. Mount the plastic clips to the wall using condition appropriate hardware, the barbs should point upwards. The end clips should be mounted 2 inches in from the rail termination on the level line. Locate any remaining clips evenly spaced between the end clips along the level line.
5. Erase any exposed marks. Remove release liner from the foam tape on back of paper rail. Mount the rail, making sure the open slot with the rollers exposed is facing down. Align the open slot on the back of the extrusion with the barbs of the plastic clips. Press the rail onto the barbs completely locking in. Press along the rail firmly to adhere the tape to the wall.
6. Other installation options include using double-faced tape (for smooth surfaces) or the supplied magnetic tape strips (for solid steel surfaces). In either case, wipe the back of the rail removing any dust or debris. Peel release liner and apply foam or magnet tape (evenly space along the rail). For foam tape applications, wipe down the surface where the rail will be installed.

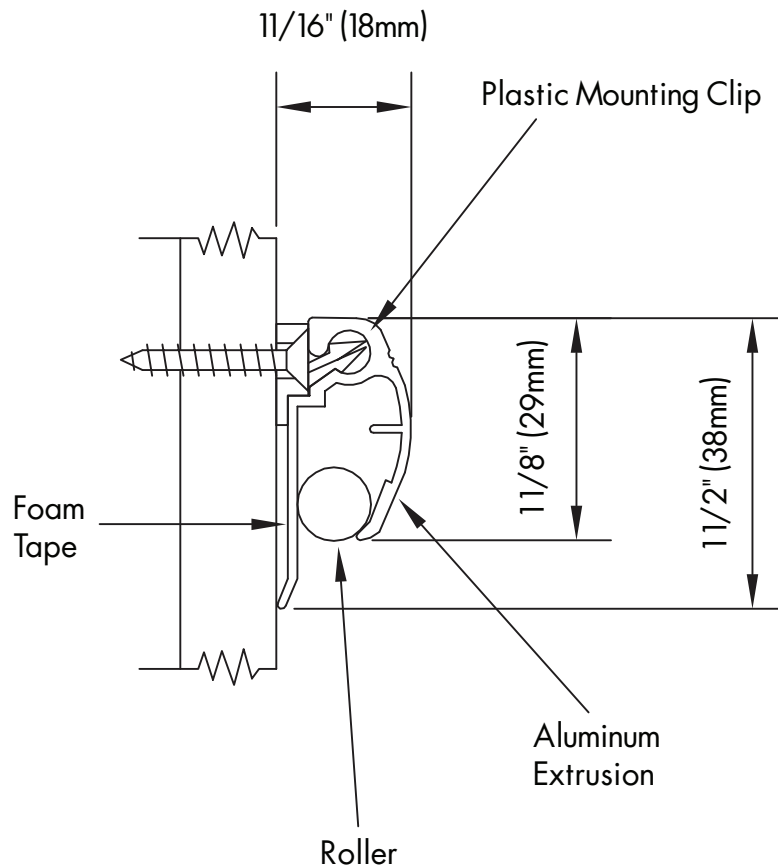

aluminum paper rail install instructions

www.walltalkers.com

walltalkers

a division of RJF International Corporation

3875 Embassy Parkway
Fairlawn, OH 44333
PH: 800.820.9255 • Fax: 330.688.7703

® is a registered trademark of RJF International Corporation.

7075APR3I11 09/10